

**märklin**  
HO

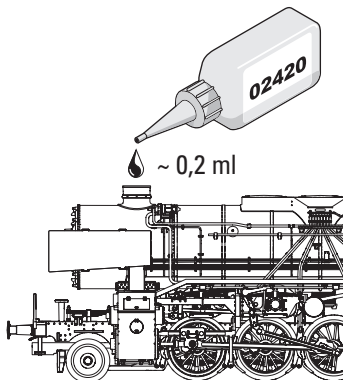

---

Rauchsatz  
**7226**

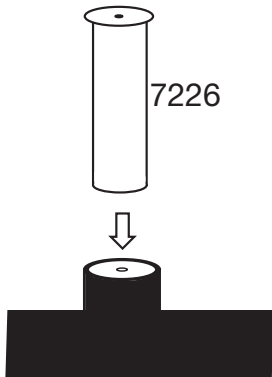



**Achtung:** der Kamin der Lok wird bei Betrieb des Rauchgenerators (mit oder ohne Rauchöl) heiß. Verbrennungsgefahr.

**Important:** The smoke stack on the locomotive becomes hot when the smoke generator is operated (with or without smoke fluid). Danger of burns.

**Attention :** Lors de l'exploitation du générateur de fumée (avec ou sans huile fumigène), la cheminée de la locomotive chauffe. Risque de brûlure.

**Let op:** De schoorsteen van de loc wordt bij het gebruik van de rookgenerator ( met of zonder rookvloeistof) heet. Gevaar voor verbranden

**¡ATENCIÓN!** : la chimenea de la locomotora alcanza temperaturas muy altas durante el funcionamiento del generador de humo (con o sin aceite de humo), por lo cual existe peligro de sufrir quemaduras.

**Attenzione:** durante il funzionamento dell'apparato fumogeno (con o senza olio fumogeno) il camino della locomotiva diventa caldo. Pericolo di scottatura.

**VARNING:** När rökgeneratoren är aktiverad (med eller utan rökvätska) blir lokets skorsten mycket het. Varning för brännskador.

**Bemærk:** Lokomotivets kamin bliver varm, når røggeneratoren er i drift (med eller uden røgolie). Fare for forbrændinger.

**Wartung • Service • Entretien • Onderhoud •  
El mantenimiento • Manutenzione • Underhåll • Service**

**1**

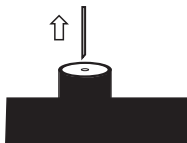

**2**

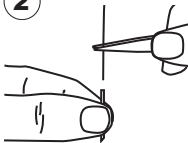

**3**

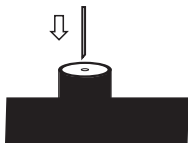

Gebr. Märklin & Cie. GmbH  
Stuttgarter Straße 55 - 57  
73033 Göppingen  
Germany  
[www.maerklin.com](http://www.maerklin.com)



[www.maerklin.com/en/imprint.html](http://www.maerklin.com/en/imprint.html)

687510/0817/Sc6Ef  
Änderungen vorbehalten  
© Gebr. Märklin & Cie. GmbH